

Main Product Characteristics

V_{DSS}	60V
$R_{DS(on)}$	70mΩ(typ)
I_D	2.7A

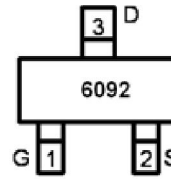

SOT-23



Marking and Pin Assignment

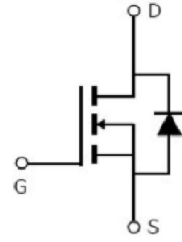

Schematic Diagram

Features and Benefits

- Advanced MOSFET process technology
- Special designed for PWM, load switching and general purpose applications
- Ultra low on-resistance with low gate charge
- Fast switching and reverse body recovery
- 150°C operating temperature
- Lead free product



Description

It utilizes the latest trench processing techniques to achieve the high cell density and reduces the on-resistance with high repetitive avalanche rating. These features combine to make this design an extremely efficient and reliable device for use in power switching application and a wide variety of other applications.

Absolute Max Rating

Symbol	Parameter	Max.	Units
$I_D @ TC = 25^\circ C$	Continuous Drain Current, $V_{GS} @ 10V$	2.7 ①	A
I_{DM}	Pulsed Drain Current ②	10.8	
$P_D @ TC = 25^\circ C$	Power Dissipation ③	1.25	W
	Linear Derating Factor	0.01	W/°C
V_{DS}	Drain-Source Voltage	60	V
V_{GS}	Gate-to-Source Voltage	± 20	V
$T_J \quad T_{STG}$	Operating Junction and Storage Temperature Range	-55 to + 150	°C

Thermal Resistance

Symbol	Characteristics	Typ.	Max.	Units
R _{θJA}	Junction-to-Ambient (t ≤ 10s)④	—	99	°C/W
	Junction-to-Ambient (PCB mounted, steady-state) ④	—	100	

Electrical Characteristics @T_A=25°C unless otherwise specified

Symbol	Parameter	Min.	Typ.	Max.	Units	Conditions
V _{(BR)DSS}	Drain-to-Source breakdown voltage	60	—	—	V	V _{GS} = 0V, I _D = 250μA
R _{DS(on)}	Static Drain-to-Source on-resistance	—	70	92	mΩ	V _{GS} =10V, I _D = 2.7A
V _{GS(th)}	Gate threshold voltage	1	—	2.5	V	V _{DS} = V _{GS} , I _D = 250μA
I _{DSS}	Drain-to-Source leakage current	—	—	1	μA	V _{DS} =60V, V _{GS} =0V
I _{GSS}	Gate-to-Source forward leakage	—	—	100	nA	V _{GS} =20V
	Gate-to-Source reverse leakage	-100	—	—		V _{GS} = -20V
Q _g	Total gate charge	—	12	—	nC	I _D = 4A
Q _{gs}	Gate-to-Source charge	—	3.5	—		V _{DD} =40V
Q _{gd}	Gate-to-Drain("Miller") charge	—	3.7	—		V _{GS} = 10V
t _{d(on)}	Turn-on delay time	—	9.2	—	nS	V _{GS} =10V, V _{DS} =25V, R _{GEN} =50Ω I _D =1.2A
t _r	Rise time	—	16.7	—		
t _{d(off)}	Turn-Off delay time	—	35.4	—		
t _f	Fall time	—	8.6	—		
C _{iss}	Input capacitance	—	641	—	pF	V _{GS} = 0V V _{DS} = 25V f =1MHz
C _{oss}	Output capacitance	—	48	—		
C _{rss}	Reverse transfer capacitance	—	38	—		

Source-Drain Ratings and Characteristics

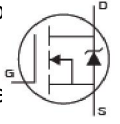
Symbol	Parameter	Min.	Typ.	Max.	Units	Conditions
I _S	Continuous Source Current (Body Diode)	—	—	2.7 ①	A	MOSFET symb showing the integral reverse p-n junction diode. 
I _{SM}	Pulsed Source Current (Body Diode)	—	—	10.8	A	
V _{SD}	Diode Forward Voltage	—	0.85	1.3	V	

Test Circuits and Waveforms:

EAS test circuits:

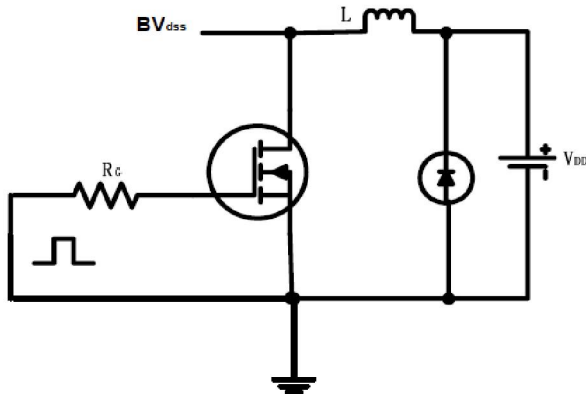

Gate charge test circuit:

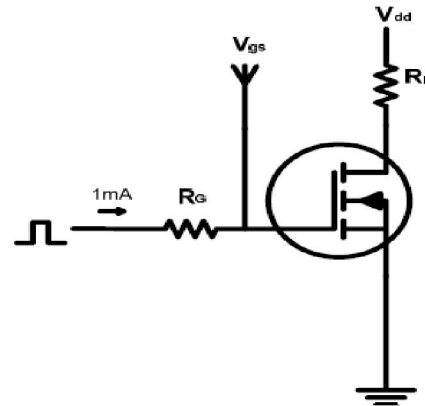

Switch Time Test Circuit:

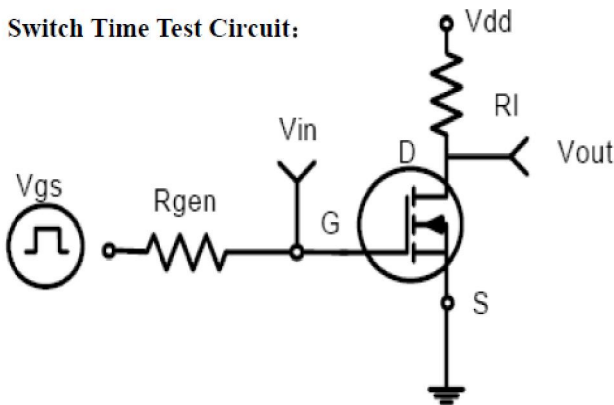

Switch Waveforms:

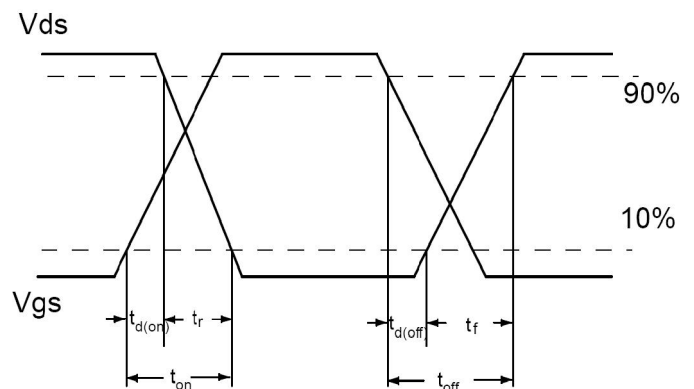

Notes:

- ① Calculated continuous current based on maximum allowable junction temperature. Package limitation current is 75A.
- ② Repetitive rating; pulse width limited by max. junction temperature.
- ③ The power dissipation PD is based on max. junction temperature, using junction-to-case thermal resistance.
- ④ The value of $R_{\theta JA}$ is measured with the device mounted on 1 in 2 FR-4 board with 2oz. Copper, in a still air environment with $T_A = 25^\circ C$
- ⑤ These curves are based on the junction-to-case thermal impedance which is measured with the device mounted to a large heatsink, assuming a maximum junction temperature of $T_{J(MAX)} = 175^\circ C$.

Thermal Characteristics:

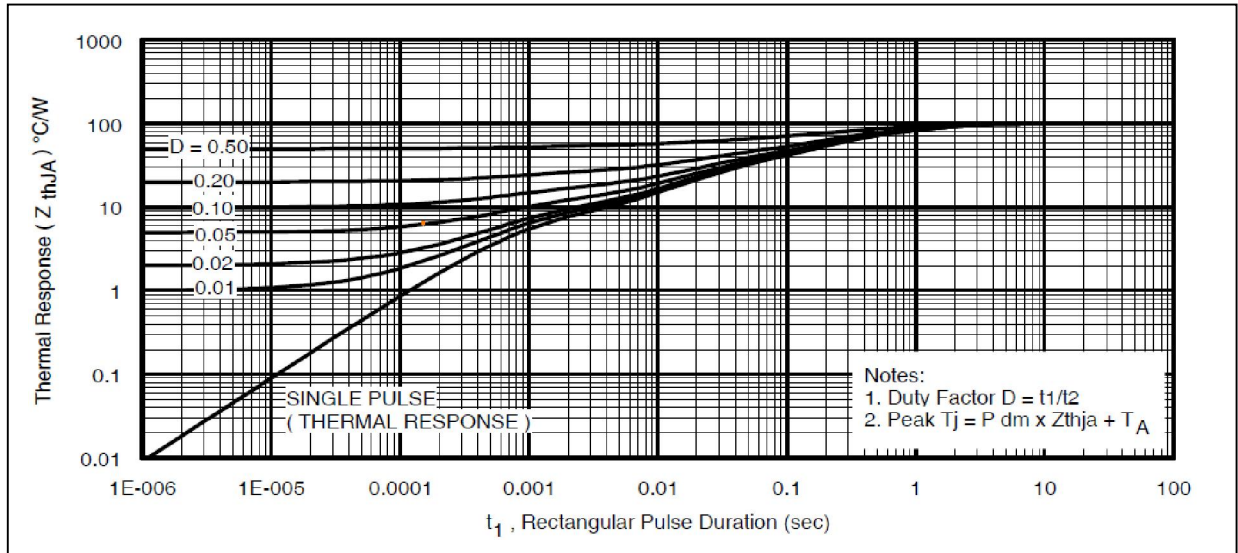
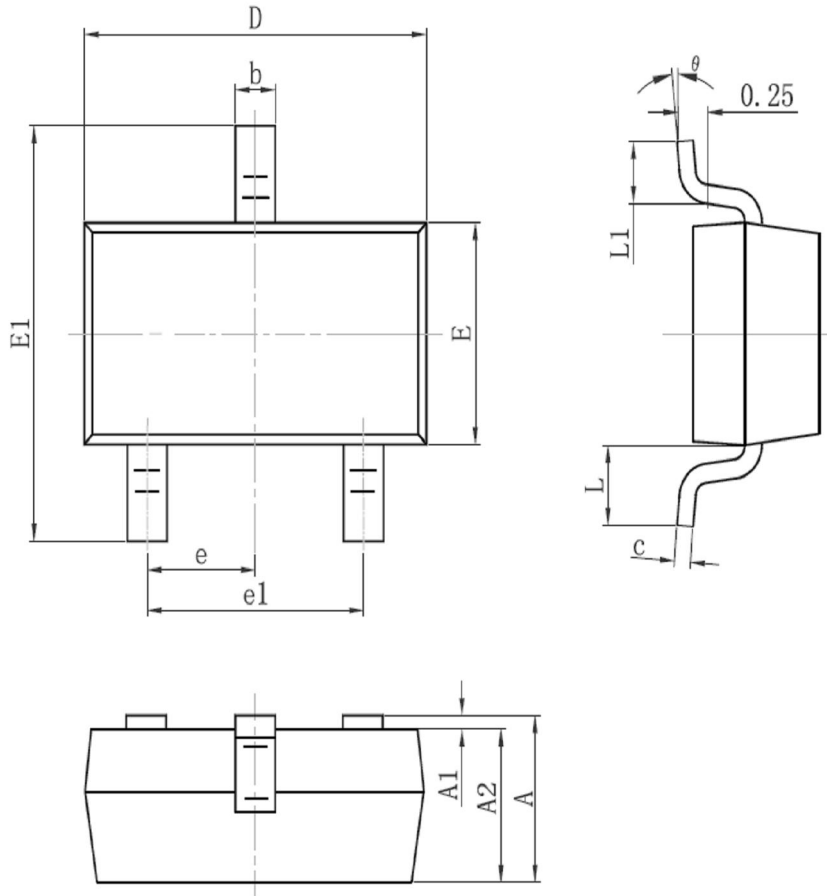

Fig 1. Typical Effective Transient Thermal Impedance, Junction-to-Ambient

Mechanical Data

SOT-23 PACKAGE OUTLINE DIMENSION



Symbol	Dimension In Millimeters		Dimension In Inches	
	Min	Max	Min	Max
A	0.900	1.150	0.035	0.045
A1	0.000	0.100	0.000	0.004
A2	0.900	1.050	0.035	0.041
b	0.300	0.500	0.012	0.020
c	0.080	0.150	0.003	0.006
D	2.800	3.000	0.110	0.118
E	1.200	1.400	0.047	0.055
E1	2.250	2.550	0.089	0.100
e	0.95TYP		0.037TYP	
e1	1.800	2.000	0.071	0.079
L	0.55REF		0.022REF	
L1	0.300	0.500	0.012	0.020
theta	0°	8°	0°	8°



Ordering and Marking Information

Device Marking: 6092

Package (Available)
SOT23
Operating Temperature Range
C : -55 to 150 °C

Devices per Unit

Package Type	Units/Tape	Tapes/Inner Box	Units/Inner Box	Inner Boxes/Carton Box	Units/Carton Box
SOT23	3000	10	30000	4	120000

Reliability Test Program

Test Item	Conditions	Duration	Sample Size
High Temperature Reverse Bias(HTRB)	$T_j=125^{\circ}\text{C}$ to 150°C @ 80% of Max $V_{DSS}/V_{CES}/V_R$	168 hours 500 hours 1000 hours	3 lots x 77 devices
High Temperature Gate Bias(HTGB)	$T_j=150^{\circ}\text{C}$ @ 100% of Max V_{GSS}	168 hours 500 hours 1000 hours	3 lots x 77 devices